

IDEAL VT100TA

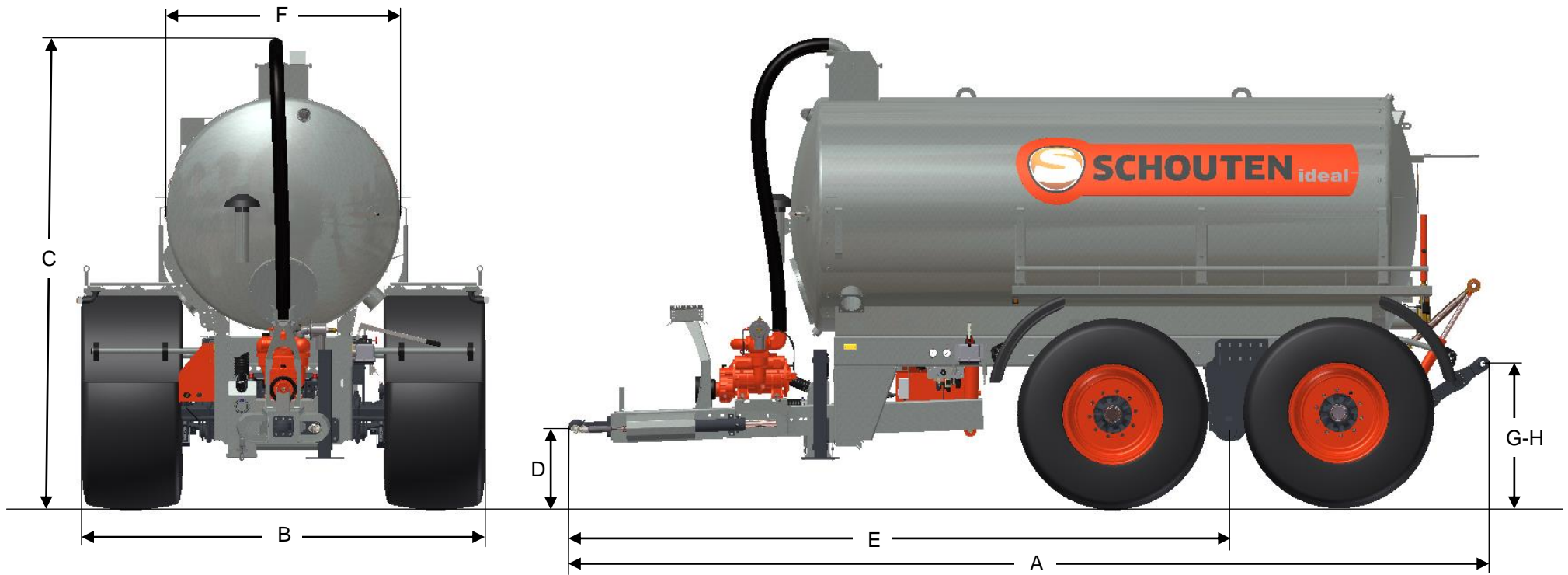

DIMENSIONS

A	LENGTH	6612 MM	E	DISTANCE HITCH - TANDEM	4738 MM
B	WIDTH	2935 MM	F	TANK DIAMETER	1700 MM
C	HEIGHT	3425 MM	G	LIFT HEIGHT MIN.	235 MM
D	HITCH HEIGHT	400-700 MM	H	LIFT HEIGHT MAX.	990 MM

IDEAL VT100TA

MACHINE INFORMATION

TYPE	VT100TA
WEIGHT	5.740 KG
TANK DIMENSIONS	Ø1700X4040 MM
TANK VOLUME	10.000 L
LEVEL INDICATOR	FLOAT POINTER
UNDERCARRIAGE	TANDEM-AXLE
TYPE OF TANDEM	BPW BRAKED
CARRYING CAPACITY TANDEM	14.000 KG
TIRES	710/50R26.5

SUPPORT LEG	HYDR. DA
VACUUM PUMP	B&P MEC11000
CAPACITY VACUUM PUMP	11.137 L/MIN
VACUUM PUMP DRIVE	PTO 540/1000RPM
MOISTURE TRAP CAPACITY	15.500 L/MIN
LIFT POSSIBILITIES	GRASSLAND/BLACK SOIL
LIFT CAPACITY	3.500 KG
LIFT SYSTEM	4-POINT CAT III

OPTIONS

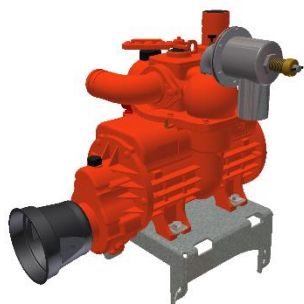

B&P MEC13500

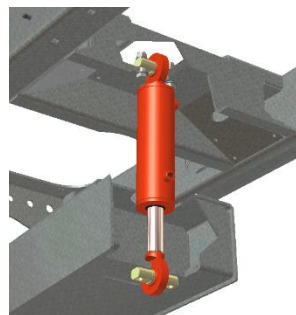

HYDR. DRAWBAR SUSPENSION

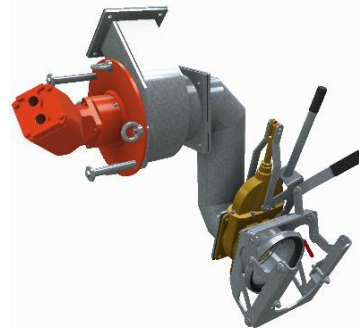

TURBO-FILLER 8-6



DOCKING FILLING ARM 8"



FILLING ARM 10" TURBO